

PROVISION FOR ATF16V8B AS A REPLACEMENT TO U2, U3

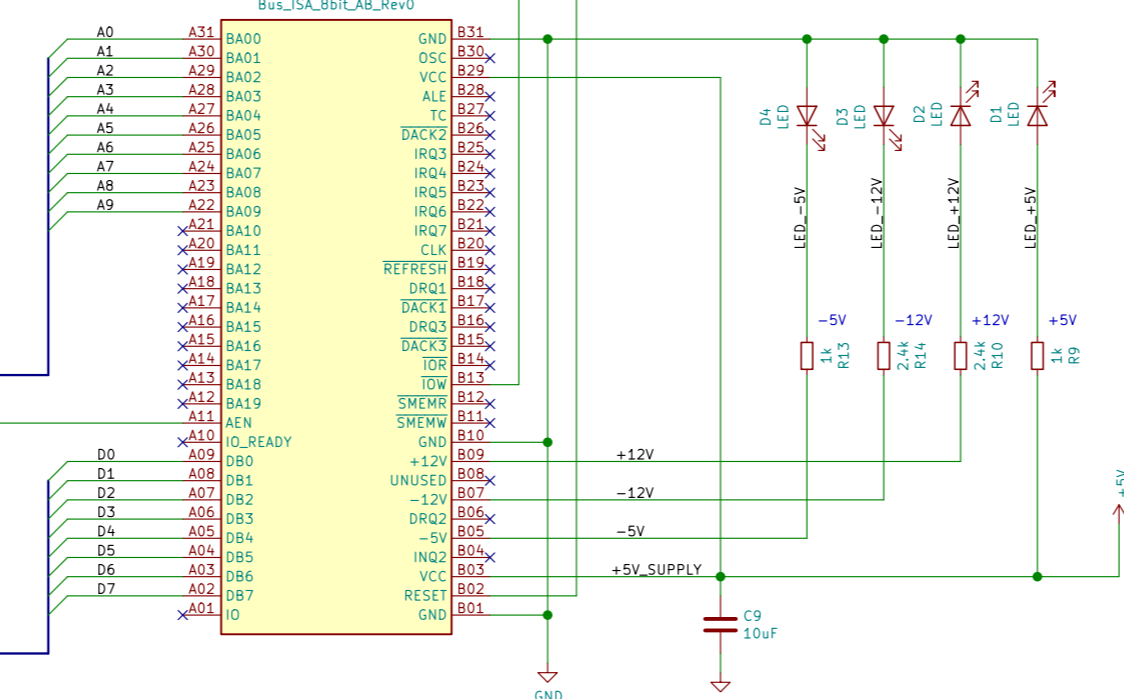
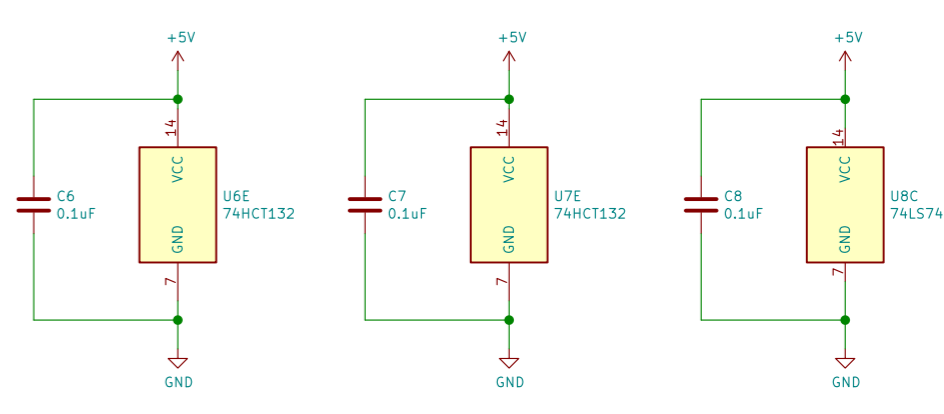
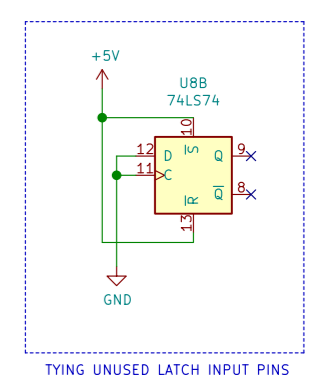
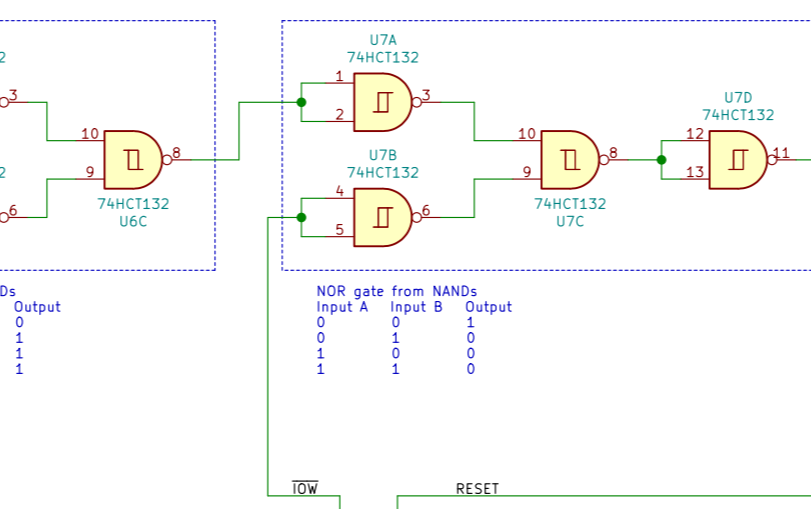
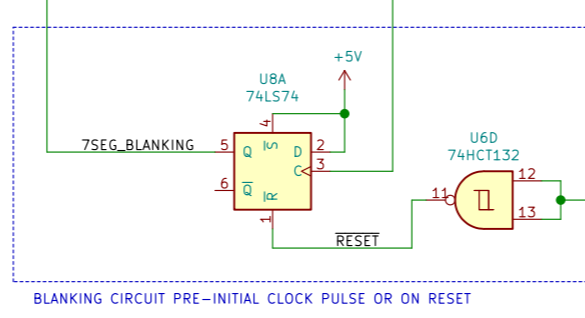

NOTICE: WARRANTY DISCLAIMED PER 5.1 OF CERN-OHL-P v2
 LIABILITY EXCLUDED AND LIMITED PER 5.2 OF CERN-OHL-P v2
 ACKNOWLEDGEMENT: BASED ON SCHEMATICS BY SERGEY KISELEV 2012